

x 2

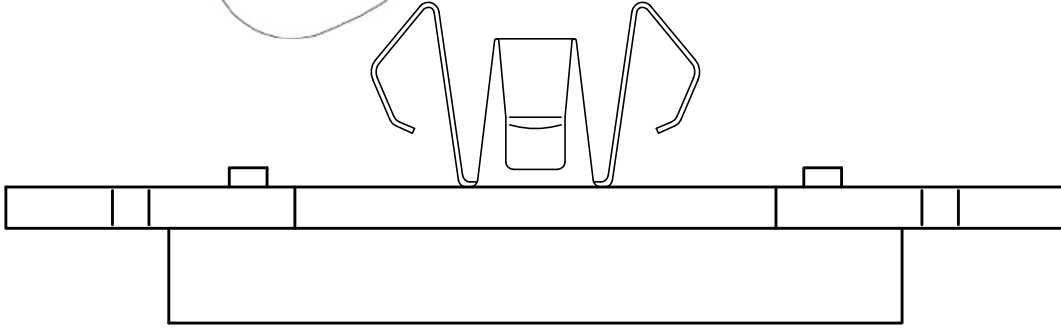

x 2

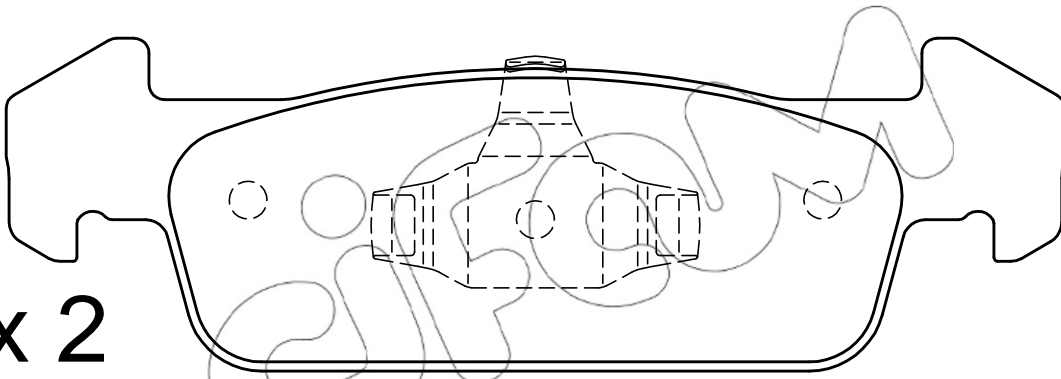
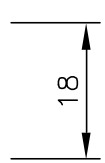
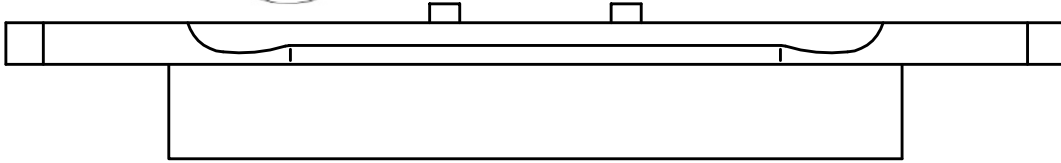
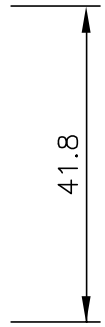
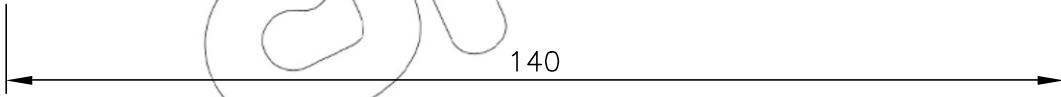
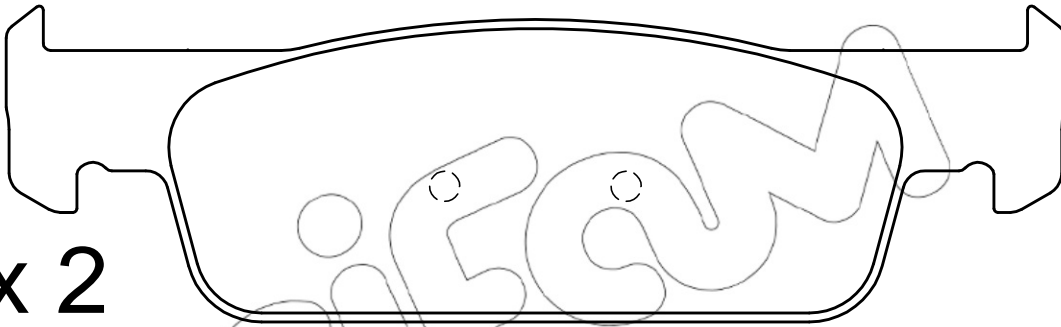

ifam