



# INSTALLATION MANUAL

## C-3426 Arnott New Coil Spring Conversion Kit Cadillac XTS (Epsilon II)



**Engineered to Ride, Built to Last<sup>®</sup>**

# CONGRATULATIONS ON YOUR PURCHASE OF AN ARNOTT® SUSPENSION PRODUCT

WE AT ARNOTT LLC ARE PROUD TO OFFER A HIGH QUALITY PRODUCT WITH ALL THE TECHNICAL SUPPORT YOU NEED. THANK YOU FOR YOUR CONFIDENCE IN US AND OUR PRODUCT.

Proper installation is essential to experience and appreciate the benefits of this system. Please take a moment to review these installation instructions before you begin to install these components on your vehicle. The removal and installation of air suspension products should only be performed by a fully qualified and certified automotive professional.

It is equally important to be aware of all necessary safety measures while installing your new Air Suspension System. This includes proper lifting and immobilizing of the vehicle and isolation of any stored energy to prevent personal injury or property damage.

## GENERAL INFORMATION

Reading this manual signifies your agreement to the terms of the general release, waiver of liability, and hold harmless agreement, the full text of which is available at [www.arnottinc.com](http://www.arnottinc.com) and [www.arnotteurope.com](http://www.arnotteurope.com).



### WARNING:

The air suspension system is under pressure (up to 10 bar, or 150 lbf/in). Verify pressure has been relieved and disconnect power to the air suspension system prior to disassembly. Do not allow dirt or grease to enter the system. Always wear standard hand, ear, and eye protection when servicing the air suspension system.

- Not to be stored below 5°F (-15°C) and above 122°F (50°C).
- Avoid damage to air lines and cables.
- Removal and installation is only to be performed by fully qualified personnel.
- Use car manufacturer's diagnostic software.

### CAUTION:

Damage to the vehicle and air suspension system can be incurred if work is carried out in a manner other than specified in the instructions or in a different sequence.

To avoid the possibility of short circuits while working with electric components consult your owner's manual on how to disconnect your battery.

Consult your vehicle owner's manual, service manual, or car dealer for the correct jacking points on your vehicle and for additional care, safety and maintenance instructions. Under no circumstances should any work be completed underneath the vehicle if it is not adequately supported, as serious injuries and death can occur.

For vehicles with a "Closed Air Supply System," replacement of components requires proper adherence to procedures set forth within OE servicing literature. Failure to comply with the OE prescribed procedures can result in component damage and/or failure.

# FRONT STRUT REMOVAL

1. Raise vehicle and remove the front wheel(s). (Figure 1)



FIGURE 1

2. Disconnect the strut electrical connection from the harness. (Figures 2, 3)



FIGURE 2



FIGURE 3

3. Remove the wheel speed sensor from the hub assembly. (Figures 4, 5)

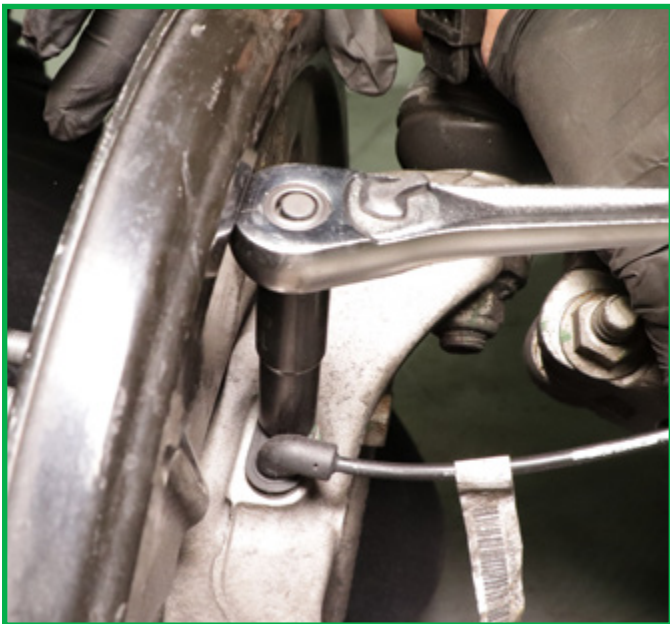

FIGURE 4



FIGURE 5

4. Remove the tie rod nut and disconnect the tie rod. (Figures 6, 7, 8)



FIGURE 6



FIGURE 7



FIGURE 8

5. Remove the two (2) brake caliper bolts. (Figures 9, 10, 11)



FIGURE 9



FIGURE 10



FIGURE 11

6. Remove and secure the brake caliper to relieve weight and tension on the brake line. (Figure 12)

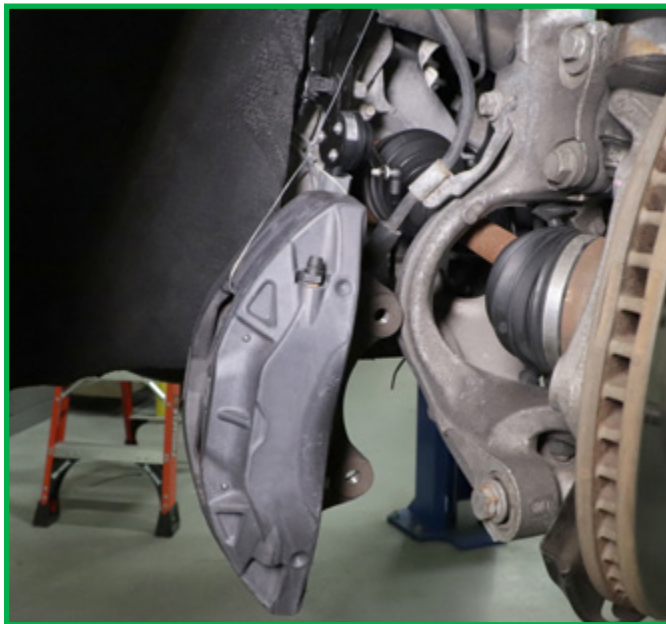

FIGURE 12

7. Remove the rotor. (Figures 13, 14)



FIGURE 13



FIGURE 14

8. Remove the axle nut. (Figures 15, 16)



FIGURE 15



FIGURE 16

9. Remove the sway bar end link nut and disconnect the sway bar end link. (Figures 17, 18)

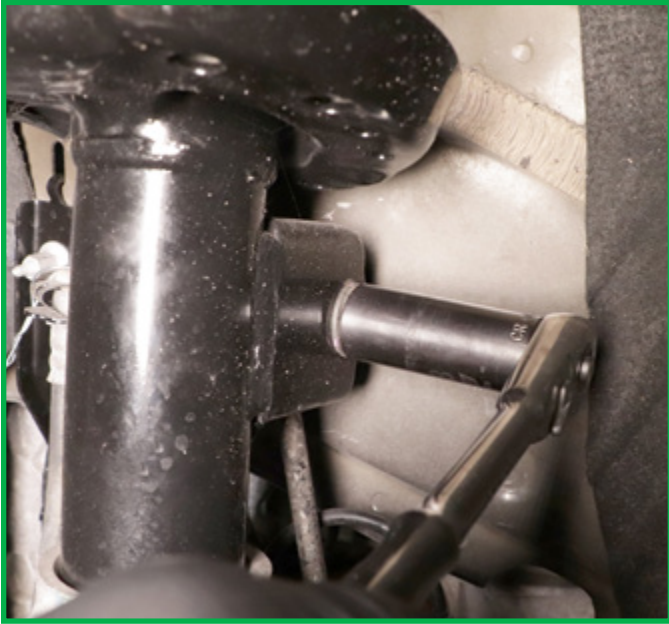

FIGURE 17

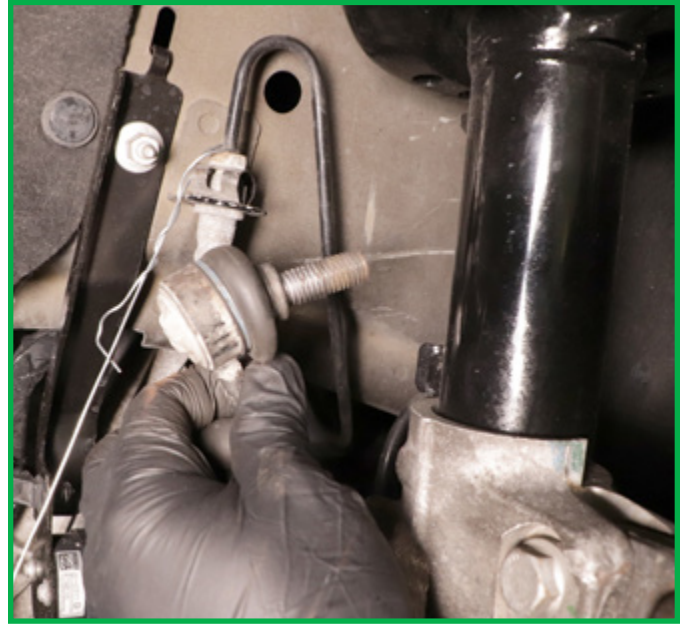

FIGURE 18

10. Remove the clevis mount pinch bolt and nut. (Figures 19, 20)



FIGURE 19

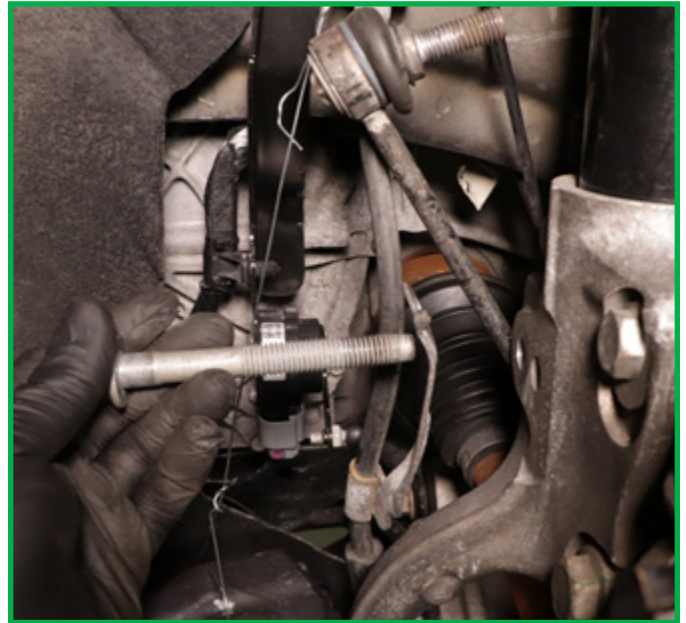

FIGURE 20



11. Remove the lower mount nut and bolt. (Figures 21, 22, 23)



FIGURE 21



FIGURE 22



FIGURE 23

12. Remove the trim covering the shock tower to gain access to the top mount. (Figures 24, 25)



FIGURE 24



FIGURE 25

13. Remove the strut top mount nut. It will be reused for installation. (Figures 26, 27)



FIGURE 26



FIGURE 27

14. Remove the strut mount washer. It will be reused for installation. (Figure 28)



FIGURE 28

15. Remove the strut and hub/knuckle/clevis mount assembly from the vehicle. (Figure 29)



FIGURE 29

16. Separate the old strut from the hub/knuckle/clevis mount assembly. (Figure 30)



FIGURE 30

17. Removal complete.

## FRONT COIL-OVER STRUT INSTALLATION



**WARNING:**

Tighten all nuts and bolts to manufacturer's specifications during the installation process.

1. Insert the new strut into the clevis mount on the hub/knuckle assembly. Ensure that the strut is seated completely and in the correct orientation, with the Arnott stickers facing the wheel studs. (Figures 31, 32)



FIGURE 31



FIGURE 32

2. Install the assembly on the vehicle. (Figure 33)



FIGURE 33

3. Reinstall the strut mount washer. (Figure 34)



FIGURE 34

4. Reinstall the top strut mount nut. Tighten to manufacturer's specifications. (Figures 35, 36)



FIGURE 35

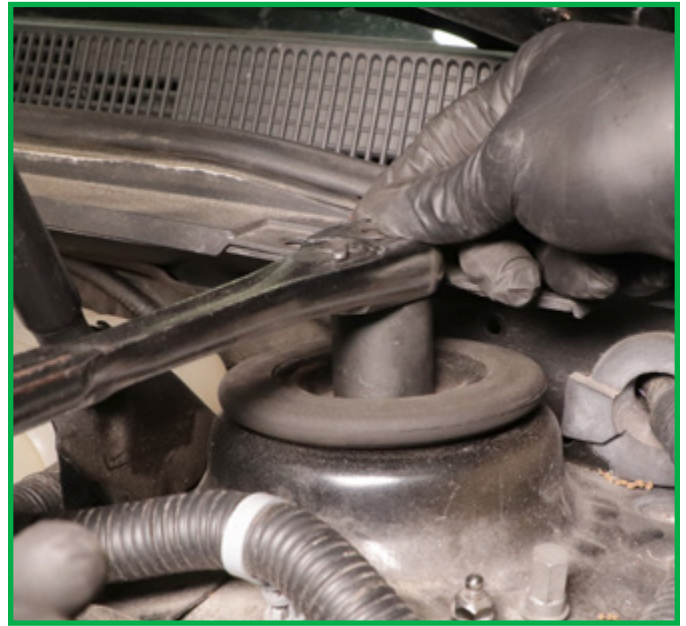

FIGURE 36

5. Reinstall the trim covering the shock tower. (Figures 37, 38)



FIGURE 37

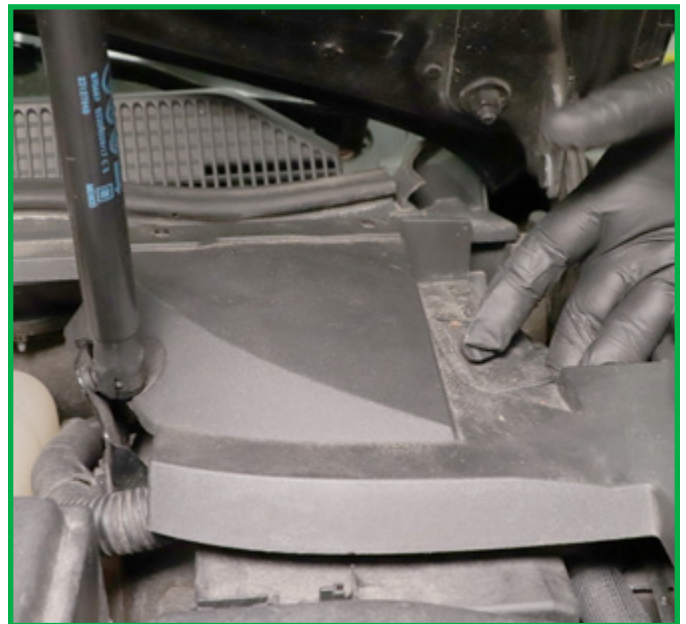

FIGURE 38

6. Reinstall the lower mount bolt and nut. Tighten to manufacturer's specifications. (Figures 39, 40, 41)



FIGURE 39



FIGURE 40



FIGURE 41

7. Reinstall the clevis mount pinch bolt and nut. Tighten to manufacturer's specifications. (Figures 42, 43)

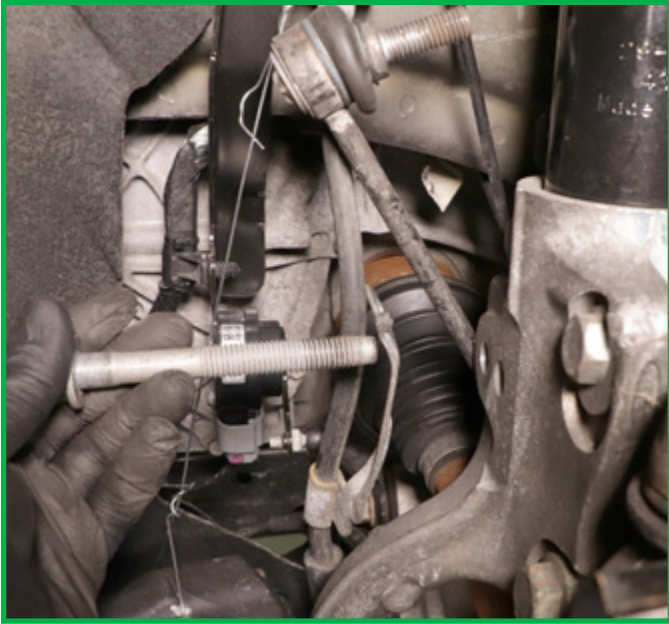

FIGURE 42



FIGURE 43

8. Reconnect the sway bar end link and reinstall the end link nut. Tighten to manufacturer's specifications. (Figures 44, 45)

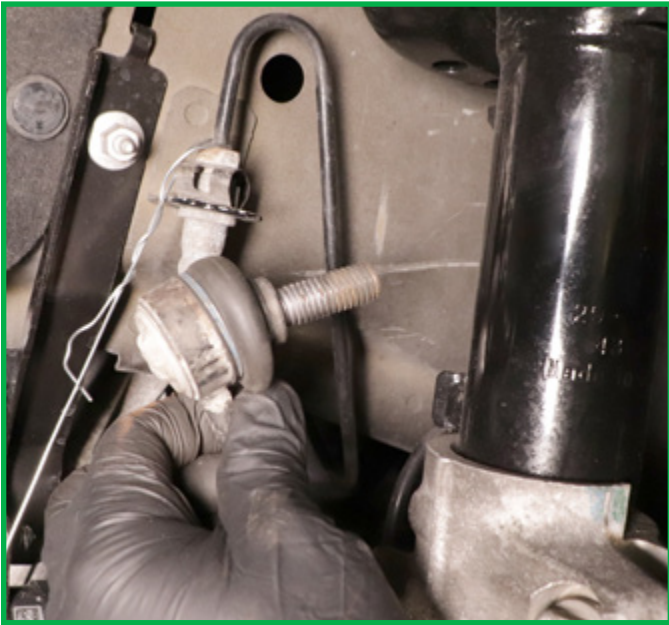

FIGURE 44

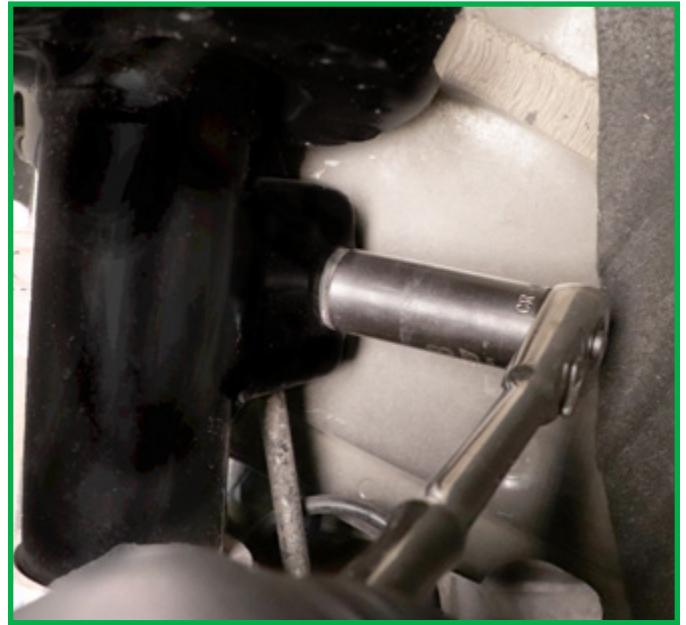

FIGURE 45



9. Reinstall the axle nut. Tighten to manufacturer's specifications. (Figures 46, 47)



FIGURE 46



FIGURE 47

10. Reinstall the rotor. (Figures 48, 49)

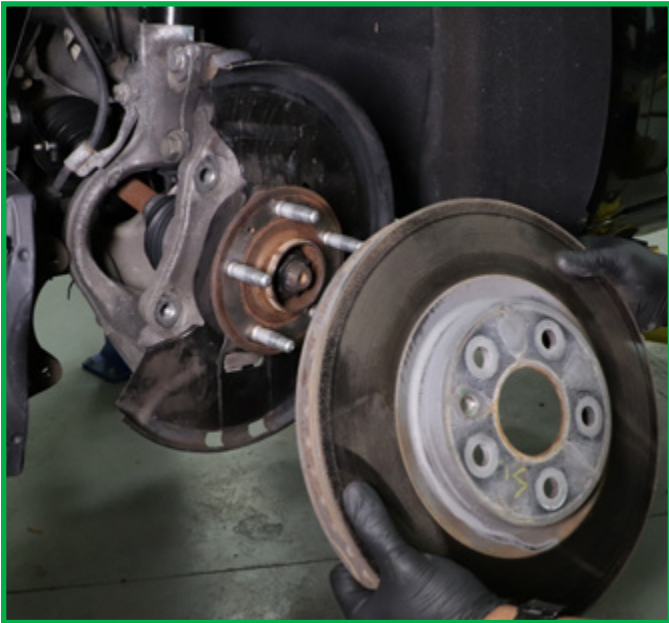

FIGURE 48



FIGURE 49

11. Reinstall the brake caliper and two (2) bolts. Tighten to manufacturer's specifications. (Figures 50, 51, 52)



FIGURE 50



FIGURE 51



FIGURE 52

12. Reconnect the tie rod and reinstall the tie rod nut. Tighten to manufacturer's specifications. (Figures 53, 54, 55)



FIGURE 53



FIGURE 54



FIGURE 55

13. Secure any remaining unused wiring brackets and harnesses safely away from friction and heat.
14. Reinstall front wheel(s).
15. Front coil-over strut installation complete.

# REAR AIR SPRING AND SHOCK REMOVAL

**NOTE:** Refer to the vehicle service manual for proper air system deflation procedures.

1. Deflate air spring(s) via the valve block. (Figure 56)



FIGURE 56

2. Remove rear wheel(s). (Figure 57)

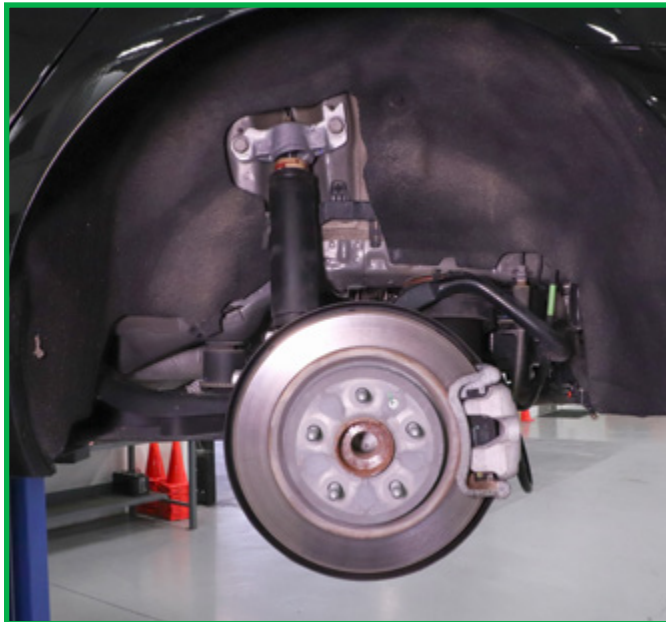

FIGURE 57

- Unclip both locking tabs on either side of the air spring top mount and pull downward. (Figure 58)

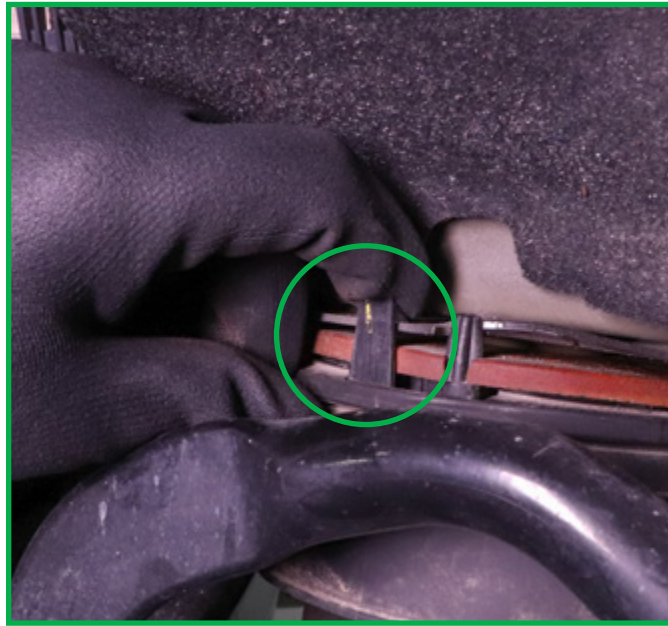

FIGURE 58

- Remove the air line fitting from the air spring. (Figure 59)



FIGURE 59

5. Remove the air spring from the vehicle. (Figure 60)



FIGURE 60

6. Disconnect the electrical connection to the shock. (Figure 61)



FIGURE 61

7. Remove the two (2) shock top mount bolts. (Figure 62)



FIGURE 62

8. Remove the lower shock mounting bolt and washer. (Figure 63)



FIGURE 63

9. Remove the shock from the vehicle. (Figure 64)



FIGURE 64

10. Removal complete.

## REAR COIL SPRING AND SHOCK INSTALLATION



**WARNING:**

Tighten all nuts and bolts to manufacturer's specifications during the installation process.

1. Secure unused air lines and electrical lines away from sources of friction and heat. (Figures 65, 66)



FIGURE 65



FIGURE 66



2. Disconnect the ride height sensor connection. (Figures 67, 68)



FIGURE 67



FIGURE 68

3. Remove the sway bar end link nut and washer. (Figures 69, 70)



FIGURE 69



FIGURE 70

4. Remove and secure the brake caliper to relieve tension on the brake lines while installing the coil spring (Figures 71, 72, 73)



FIGURE 71



FIGURE 72

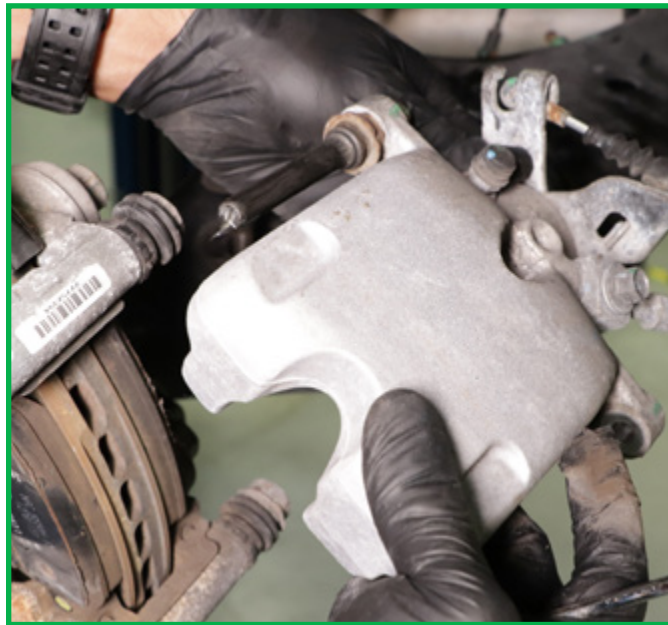

FIGURE 73

5. Remove the upper control arm nut and pull out bolt to the upper control arm. (Figures 74, 75)



FIGURE 74



FIGURE 75

6. Disconnect the wheel speed sensor wire bracket from the upper control arm. (Figure 76)



FIGURE 76

7. Remove the forward control arm bolt. (Figures 77, 78)

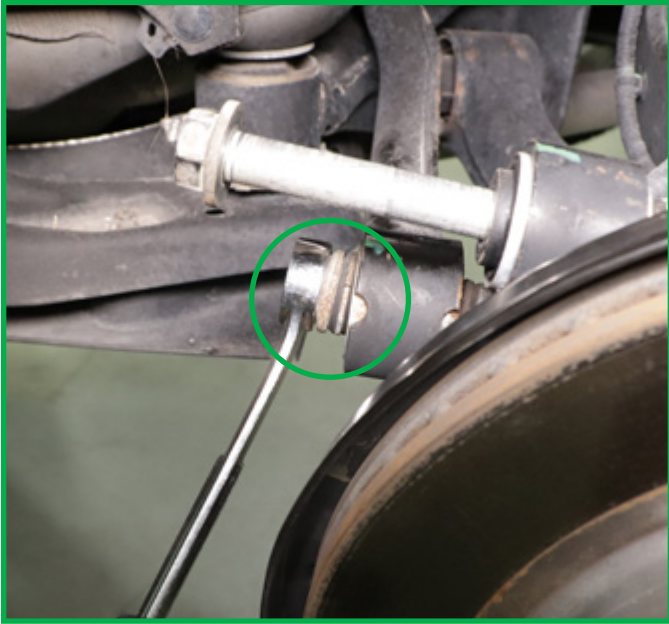

FIGURE 77



FIGURE 78

8. Install the coil spring top mount rubber isolator on to the frame of the vehicle. (Figures 79, 80)



FIGURE 79

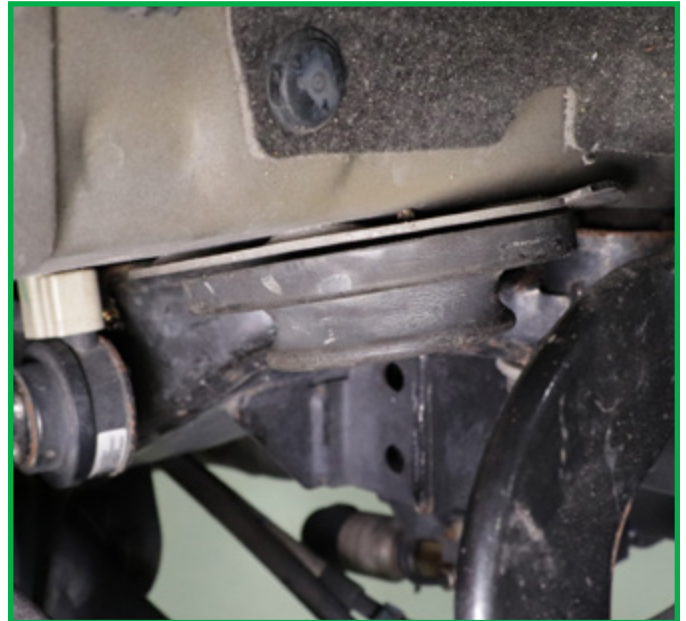

FIGURE 80

9. Install the coil spring bottom mount rubber isolator, with the nipple on the isolator facing down, sitting flush with the frame. (Figures 81, 82, 83)

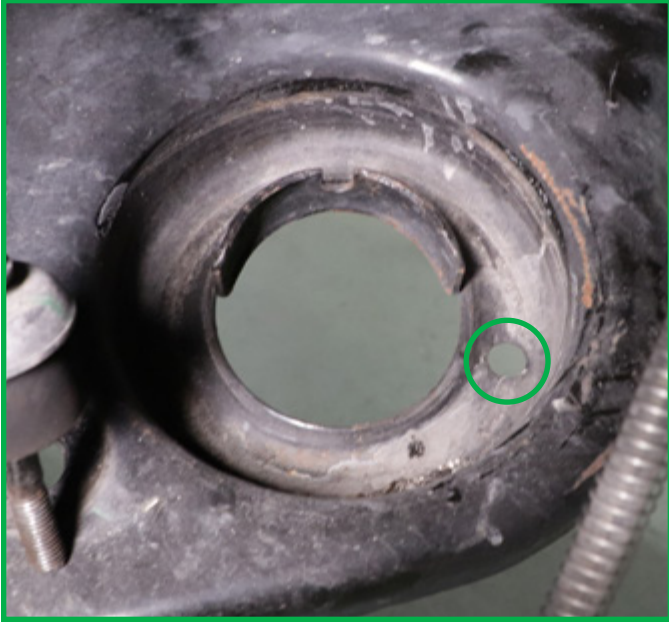

FIGURE 81



FIGURE 82



FIGURE 83

10. Install the coil spring on the vehicle, seating the top mount of the coil spring first. (Figures 84, 85)

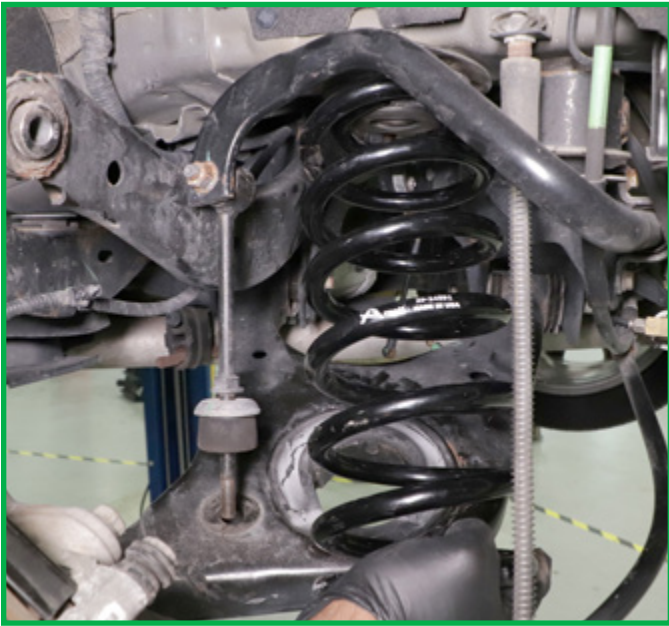

FIGURE 84

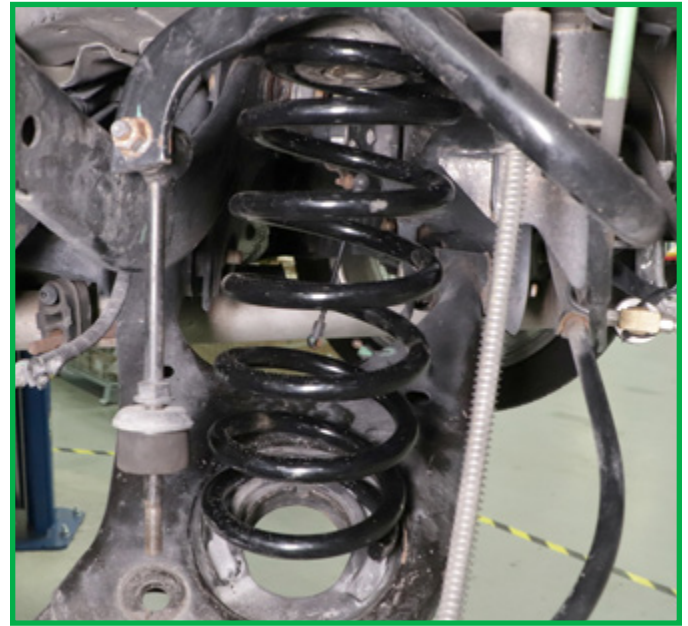

FIGURE 85

11. Use a hydraulic floor jack to assist compressing the spring to seat the bottom mount and to hold the spring in place. (Figure 86)



FIGURE 86

12. Reinstall the upper control arm bolt and nut. Tighten to manufacturer's specifications. (Figures 87, 88)



FIGURE 87



FIGURE 88

13. Reinstall the forward control arm bolt. Tighten to manufacturer's specifications. (Figure 89)



FIGURE 89

14. Reinstall the brake caliper. (Figures 90, 91)



FIGURE 90



FIGURE 91

15. Use a hoist or jack as necessary to reinstall the sway bar end link washer and nut. Tighten to manufacturer's specifications. (Figures 92, 93)



FIGURE 92



FIGURE 93



16. Reinstall the wheel speed sensor and ride height sensor. (Figures 94, 95)



FIGURE 94



FIGURE 95

17. Install the new shock on to the vehicle. (Figure 96)



FIGURE 96

18. Reinstall the two (2) shock top mount bolts. Tighten to manufacturer's specifications. (Figures 97, 98)



FIGURE 97



FIGURE 98

19. Reinstall the bottom mount bolt and washer. Tighten to manufacturer's specifications. (Figures 99, 100)



FIGURE 99



FIGURE 100

20. Reinstall the rear wheel(s).

21. Lower the vehicle.

22. Rear coil spring and shock installation complete.

# ELECTRONIC BYPASS MODULE INSTALLATION

1. Remove trim and paneling from inside the trunk on the driver's side to locate the air suspension control module. (Figures 101, 102)



FIGURE 101



FIGURE 102

2. Disconnect the harness from the suspension control module. The module will remain unplugged. (Figures 103, 104)



FIGURE 103



FIGURE 104

3. For this application, two (2) EBM modules must be used. This is because the removal of the suspension module severs other modules in the daisy chain, which will raise a handful of DTC errors if the two modules are not used together. Using the tables, schematic, and photos below, match the wires and splice them together with the T-Tap connectors. **NOTE: The EBM with the blue dot is for "Lo-Speed" or "GMLAN 2" referenced in the schematic.** (Figures 105, 106, 107, 108, 109)

	FROM	TO	PIN LOCATION	HARNESS
<b>ELECTRONIC BYPASS MODULE #1</b>	Blue	Blue	39	<b>GMLAN 1 or "HI-SPEED"</b>
	Green	White	24	
	Red	White/Blue	16	
	Black	Black	47	

FIGURE 105

	FROM	TO	PIN LOCATION	HARNESS
<b>ELECTRONIC BYPASS MODULE #2 (Blue Dot)</b>	Blue	Blue/Yellow	12, 13	<b>GMLAN 2 or "Lo-SPEED"</b>
	Green	White	14, 15	
	Red	White/Blue	16	
	Black	Black	47	

FIGURE 106

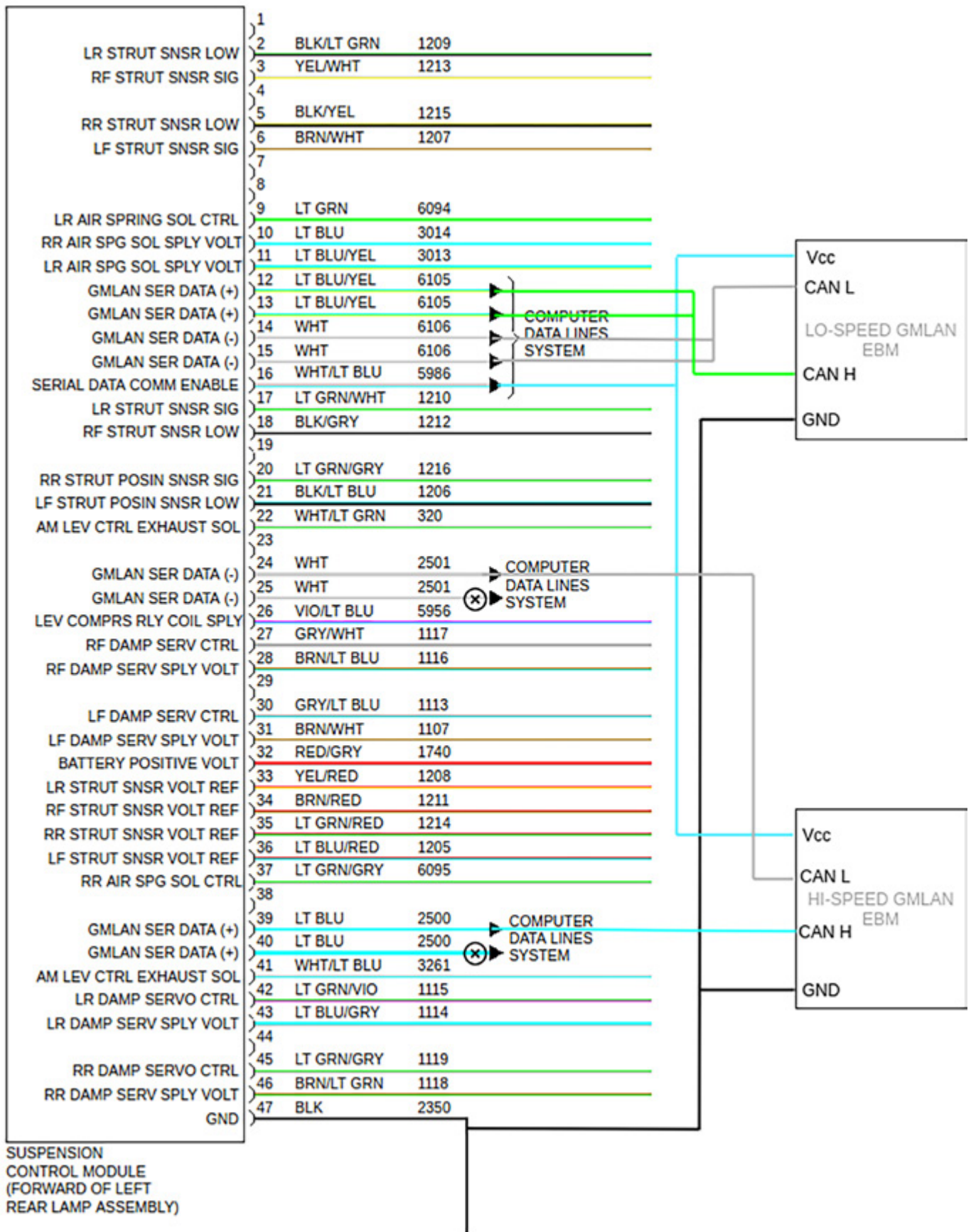

FIGURE 107

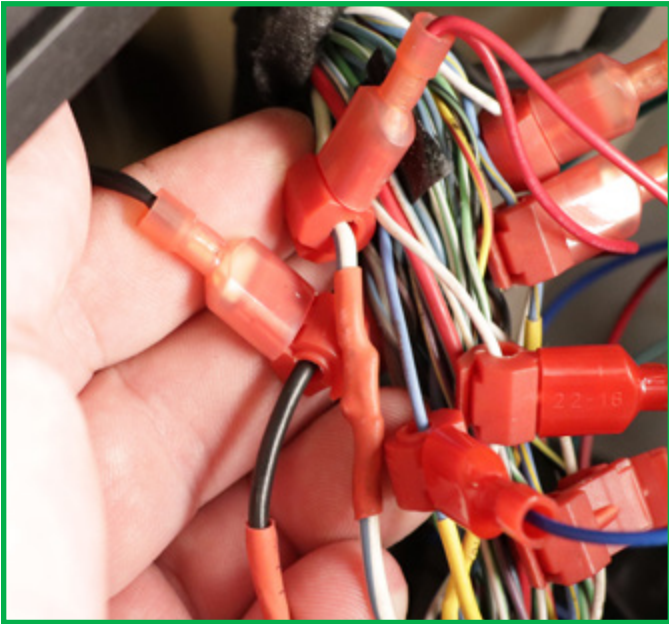

FIGURE 108

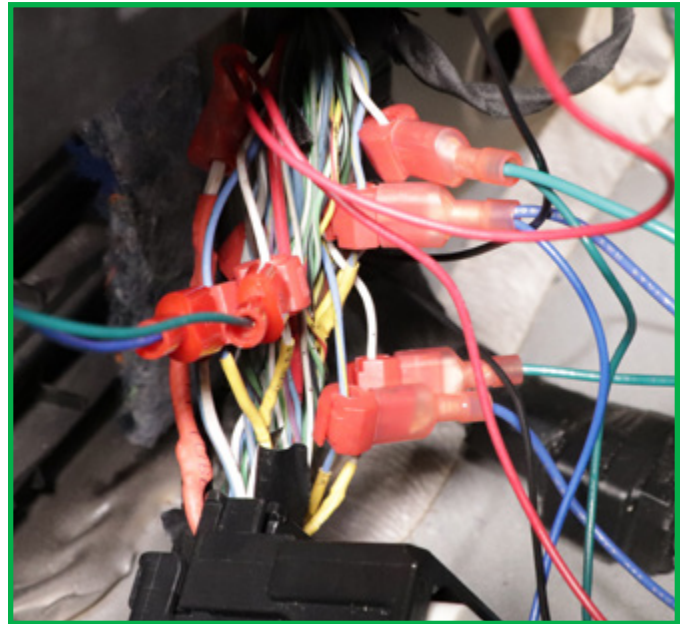

FIGURE 109

4. Connect the two (2) EBM modules. (Figures 110, 111)



FIGURE 110



FIGURE 111

5. Place the EBM's in a suitable spot free from friction or pinch points.
6. Installation complete.

# Arnott™

## Suspension Products

### Arnott US Business Office:

[www.arnottinc.com](http://www.arnottinc.com)

100 Sea Ray Drive  
Merritt Island, FL 32953

**Call:** 800.251.8993

321.868.3016

**Fax:** 321.868.3703

**Email:** [techassistance@arnottinc.com](mailto:techassistance@arnottinc.com)

### Arnott Europe Business Office:

[www.arnotteurope.com](http://www.arnotteurope.com)

Docterskampstraat 1E/1F, 3  
5222 AM 's-Hertogenbosch (NL)

**NL Phone:** +31 73 7850 580

**DE Phone:** +31 85 2087 438

**UK Phone:** +44 203 3186 124

**BE Phone:** +32 258 846 90

**ES Phone:** +34 91 901 10 56

**FR Phone:** +32 78 48 46 93

**Email:** [info@arnotteurope.com](mailto:info@arnotteurope.com)

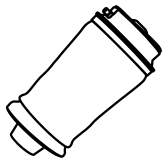

Air Springs

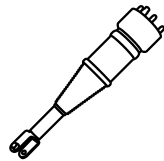

Struts

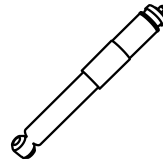

Shocks

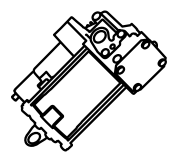

Compressors

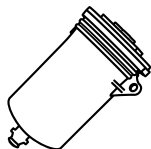

Dryers

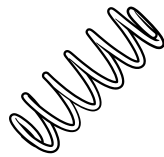

Coil Spring  
Conversion Kits

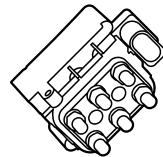

Valve Blocks

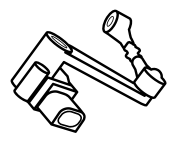

Ride Height  
Sensors