

VKMA 01256



A



- (4): Camshaft timing gauge (ref. VAG 2065A).
- (6): Locking tool (ref. VW 3359).
- (7): Locking tool (ref. VW 2064).
- (13): Pin wrench (ref. VW V159).

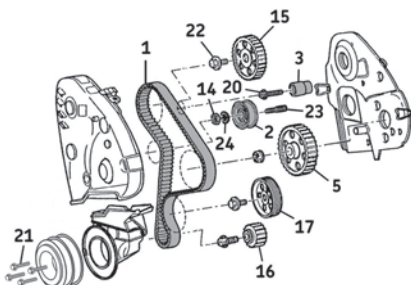

- (8): 25 Nm
- (14): 20 Nm
- (20): 20 Nm
- (21): 25 Nm
- (22): 45 Nm
- (23): 15 Nm



#### Removal

- 1) Disconnect the battery according to the vehicle manufacturing guidelines.
- 2) Prepare the vehicle for the timing replacement according to the vehicle manufacturing guidelines.
- 3) Turn cylinder n°1 up to TDC to align the marks on the flywheel/clutch casing or on the automatic drive/transmission plate (Fig. B or Fig. C or Fig. D).
- 4) Remove the cylinder head cover and lock the camshaft using the locking tool (4), by centering it (Fig. E).
- 5) Block the injection pump sprocket (5) (Fig. A):
  - Engines with injection pump sprocket in two parts: use gauge (6) (Fig. F).
  - Engines with injection pump sprocket in one part: use gauge (7) (Fig. G).
- 6) For engines with injection pump sprocket in two parts: loosen the injection pump sprocket fitting screws (8) (Fig. F).

**Note:** do not touch the pump's nut (9) (Fig. F).

- 7) Remove the crankshaft pulley, loosen the tensioner roller screw (2), then remove the timing belt (1) as well as the tensioner roller (Fig. A).
- 8) For engines with injection pump sprocket in one part: remove the idler roller (3) (Fig. A).
- 9) Remove the stud.

#### Refitting

**Caution!** Clean the bearing surfaces of the rollers.

- 10) Fit and tighten the new stud (23) to the torque of 15 Nm (Fig. A).
- 11) Check that cylinder n°1 is at TDC.
- 12) Engines with injection pump sprocket in one part: Refit the new idler roller (3) and tighten the new bolt (20) to 20 Nm (Fig. A).
- 13) Refit the new tensioner roller (2) with its new washer (24) and new nut (14). Set the positioning pin (10) in slot (11) on the engine block (Fig. H). Turn the adjusting plate (12) using the wrench (13) up to the "8 o'clock" position (Fig. H) then tighten the tensioner roller fastening nut (14) (Fig. H) by hand.
- 14) Loosen the camshaft sprocket fastening bolt by a half-turn.
- 15) Separate the camshaft sprocket from the hub and check it rotates freely around its shaft.
- 16) Refit the timing belt (1) on the following elements: crankshaft sprocket, oil pump sprocket, injection pump sprocket, idler roller (3) (according to engine), camshaft sprocket and tensioner roller (2) (Fig. A).
- 17) Tighten the camshaft sprocket fastening bolt by hand.

B

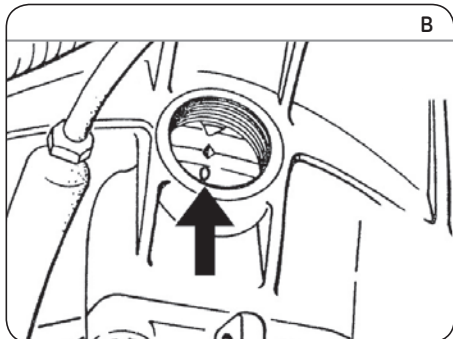

C

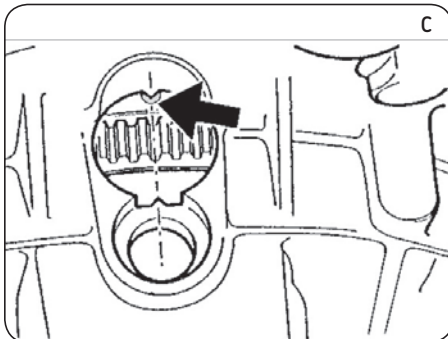

D

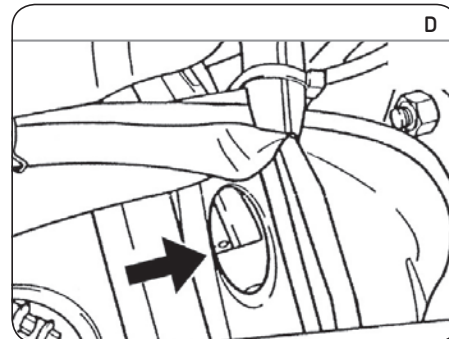

Install Confidence

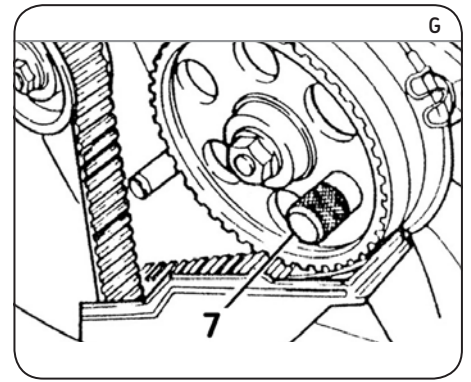
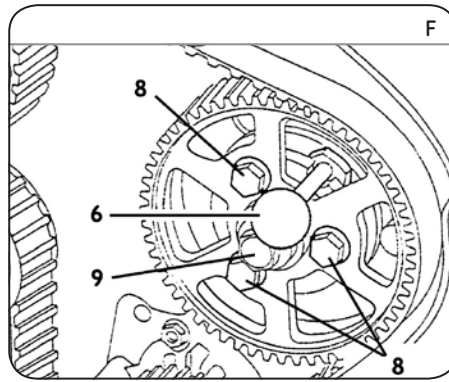
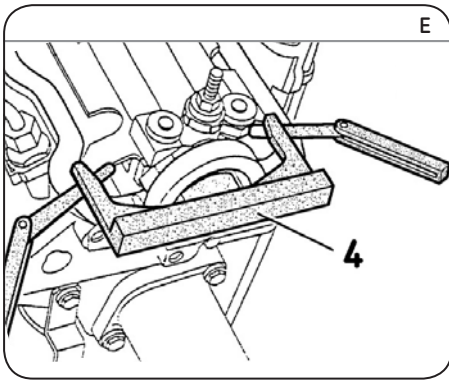

- 18) Tighten the timing belt (1): turn the adjusting plate (12) on the tensioner roller (2) **clockwise** using the wrench (13), while holding the roller's fastening screw (14) in position using a hexagon head wrench (Fig. H) until the moving pointer (18) is aligned with the notch (19) (Fig. I). Then tighten the fastening nut (14) (Fig. H) at 20 Nm.
- 19) Tighten the camshaft sprocket fastening bolt at 45 Nm.
- 20) Engines with injection pump sprocket in two parts: change the fastening bolts (8) of the injection pump sprocket and tighten them at 25 Nm (Fig. F).
- 21) Remove the locking tool (4) (Fig. E) and the gauges (6) or (7) (Fig. F and Fig. G).
- 22) Remove the wrench (13) and the hex head wrench from the fastening nut (14) (Fig. H).
- 23) Turn the crankshaft by two turns in the engine rotation direction until TDC is reached on cylinder n°1.
- 24) Check the timing adjusting marks (Fig. B or Fig. C or Fig. D) and that the injection pump sprocket can be locked using the gauges (6) or (7) (Fig. F and Fig. G).
- 25) Check the moving index adjustment (18) (Fig. I). (the moving index must be aligned with the notch (19)).

**Note:** The timing belt is tightened properly if the moving index (18) on the tension roller is aligned with the notch (19) (Fig. I).

- 26) If the marks on the tensioner roller are not aligned, proceed as follows: turn the adjusting plate (12) **counter-clockwise** to return the moving index to its initial position, then remove the timing belt. Then adjust the tension by returning to step 17).
- 27) Refit the parts in the reversed removal sequence, while applying the following:
  - For 1Z engines: 25 Nm.
  - For other engines, refer to manufacturer recommendations.

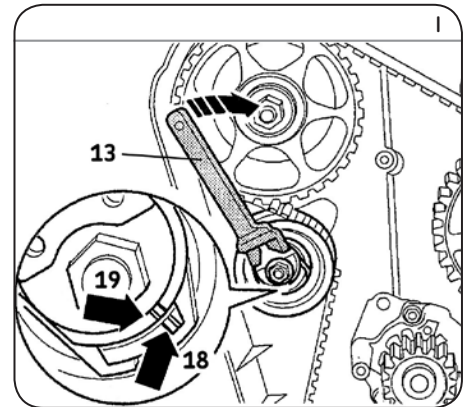
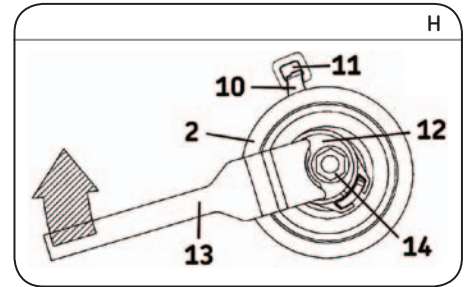

**Notice:** Always follow the vehicle manufacturer instructions when working on the engine. The SKF KITS are designed for the automotive repair professional and must be fitted using tooling used by these professionals. These instructions are to be used as a guideline only. This document is the exclusive property of SKF. Any representation, partial or full reproduction, is forbidden without prior written consent from SKF.