



LuK Service Info

Part Nr. 631 0312 09/10 – 310/310mm ZGW6

Manufacturer: DEUTZ

Model: DX160 & DX 7.10

Art.-Nr.: 631 0312 09/10

Info: New design / Neues Design / Nouvelle conception / Nuevo diseño / Nuovo disegno / Nuovo segno



631 0312 09 = ONLY AVAILABLE AS A REPSET

631 0312 10 = 631 0312 09 + 500 0679 00 + 410 0045 40



This new design utilises the latest clutch technology, using a vented housing for improved cooling and heat dispersal. Fully interchangeable with existing clutches with no modifications required to vehicle or flywheel. A new fixation bolt set 411 0195 10 12 x M8 x 1.25 x 65mm + Conical washer is supplied with new designs to accommodate the lower housing.



Este nuevo diseño utiliza la última tecnología de embrague, utilizando una carcasa ventilada para mejorar la refrigeración y la dispersión del calor. Totalmente intercambiable con embragues existentes sin necesidad de modificaciones en el vehículo o volante de inercia. Un nuevo juego de pernos de fijación 411 0195 10 12 x M8 x 1,25 x 65mm + Arandela cónica se suministra con nuevos diseños para acomodar la carcasa



Dieses neue Design nutzt die neueste Kupplungstechnologie und verwendet ein belüftetes Gehäuse für eine verbesserte Kühlung und Wärmeableitung. Vollständig austauschbar mit vorhandenen Kupplungen, ohne dass Änderungen am Fahrzeug oder Schwungrad erforderlich sind. Ein neuer Befestigungsbolzensatz 411 0195 10 12 x M8 x 1,25 x 65mm + Konische Unterlegscheibe wird mit neuen Designs geliefert, um das untere Gehäuse aufzunehmen.



Questo nuovo design utilizza la più recente tecnologia della frizione, utilizzando un alloggiamento ventilato per migliorare il raffreddamento e la dispersione del calore. Completamente intercambiabile con frizioni esistenti senza necessità di modifiche al veicolo o al volante. Un nuovo set di bulloni di fissaggio 411 0195 10 12 x M8 x 1,25 x 65mm + Rondella conica viene fornito con nuovi design per adattarsi all'alloggiamento inferiore.



Cette nouvelle conception utilise la dernière technologie d'embrayage, en utilisant un boîtier ventilé pour améliorer le refroidissement et la dispersion de la chaleur. Entièrement interchangeable avec les embrayages existants sans modification requise du véhicule ou du volant d'inertie. Un nouveau jeu de boulons de fixation 411 0195 10 12 x M8 x 1,25 x 65mm + Rondelle conique est fourni avec de nouveaux designs pour accueillir le boîtier inférieur.

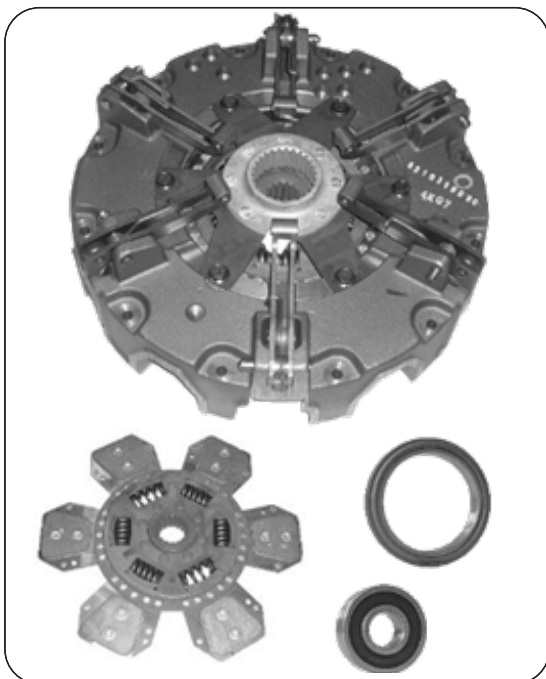

Call : +44 (0) 1432 264264
aftermarket.schaeffler.com

SCHAEFFLER
REP>XPERT