

ELPARTS

Tagfahrleuchtensatz

Einbauhinweis

DE

EN

FR

DE Tagfahrleuchtensatz

Das Steuergerät erkennt über die Ladespannung an der Batterie, wann der Motor läuft und schaltet dann das Tagfahrlicht automatisch zu. Dies macht einen zusätzlichen Anschluss an die Klemme 15 überflüssig.

Inhalt:

- 2 x LED Leuchte
- 2 x Halterung
- 4 x Schrauben
- 4 x Unterlegscheiben
- 1 x Steuergerät

Technische Daten:



Schaltplan

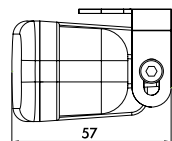
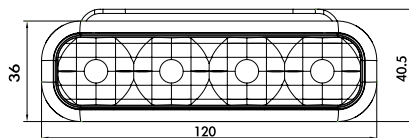
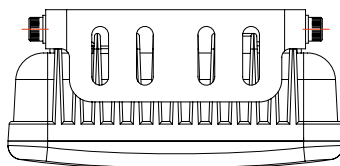
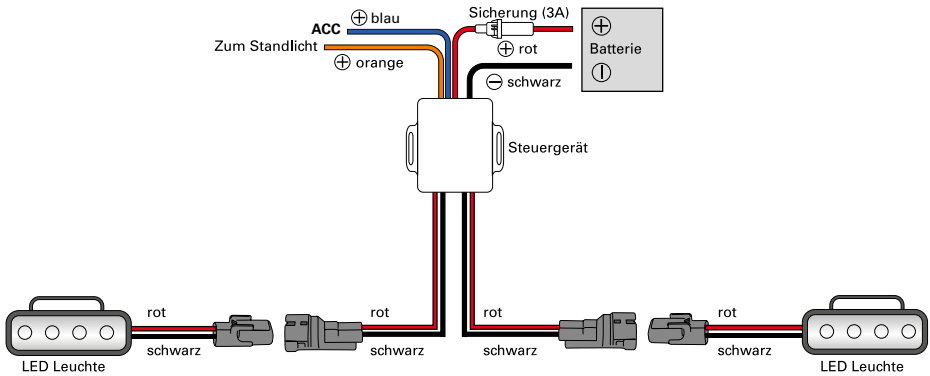

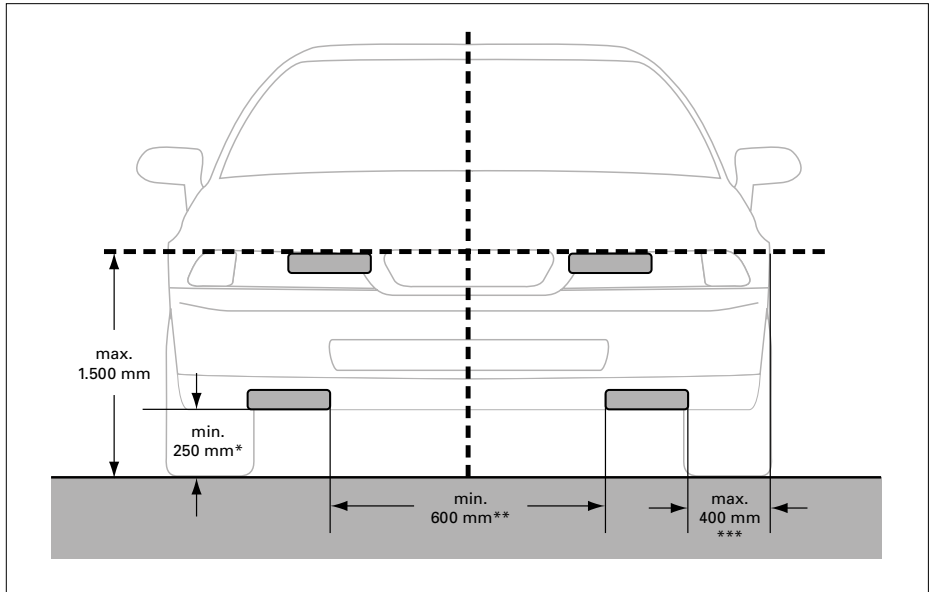

ACHTUNG

- Laut ECE R-48 dürfen nur zwei Positionslampen, nach vorne, aktiv sein. Soll die Positionslichtfunktion von den LED-Leuchten übernommen werden, muss das serienmäßig deaktiviert werden.

Montage

- * Bei Verwendung als Positionslicht min. 350 mm.
- ** Bei Fahrzeugen mit einer Breite von < 1.300 mm muss der Abstand min. 400 mm betragen.
- *** Bei Verwendung als PO-Licht max. 400 mm. Wird die Leuchte nur für die Tagfahrlichtfunktion eingesetzt, entfällt diese Einschränkung.

Daytime Running Light Set

EN The control box detects through the charging tension when the engine is running and switch on the LED DRL automatically. This makes an additional connection to the ignition unnecessary.

Kit includes:

- 2 x lamp
- 2 x taps
- 4 x screw
- 4 x washer
- 1 x receiver

Technical data:



Electrical connection

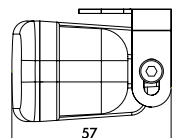
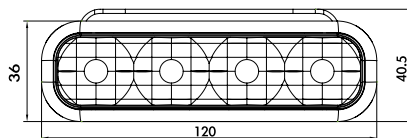
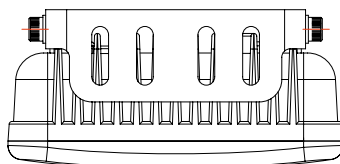
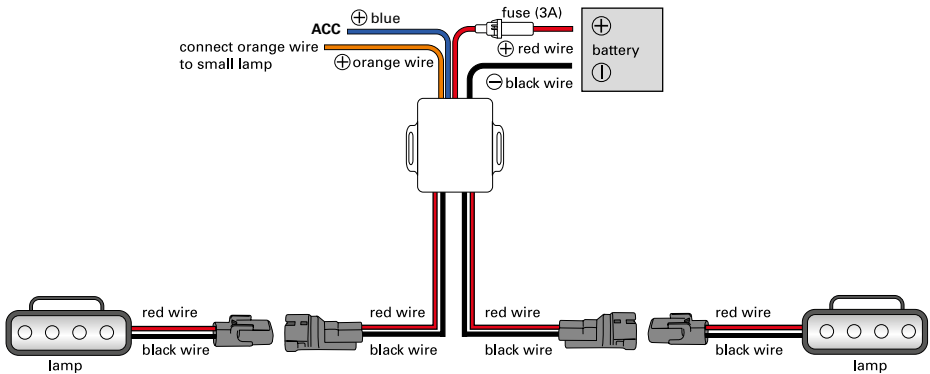

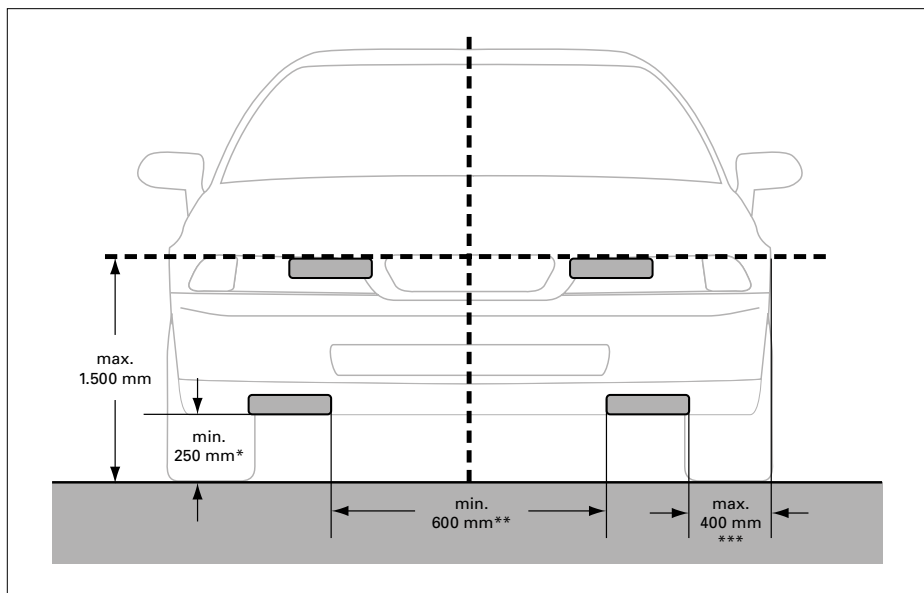

NOTE

- According to ECE R-48, only two front position lights may be active. If the position light function is to be taken over by the LED lights, the standard position light must be deactivated.

Montage

- * When used with position light min. 350 mm
- ** With vehicles less than 1.300 mm wide, the distance has to be at least 400 mm.
- *** When used with position light max. 400 mm. If the light is only used for the daytime running light function, this restriction does not apply.

Kit de feu de roulage de jour

L'appareil de commande reconnaît à partir de la tension de charge au niveau de la batterie quand le moteur est en marche et allume alors automatiquement les feux de circulation diurne. Ceci rend une connexion supplémentaire à la borne 15 superflue.

Contenu :

- 2 feux DEL
- 2 supports
- 4 vis
- 4 rondelles de calage
- 1 appareil de commande

Caractéristiques techniques :



FR

Schéma électrique

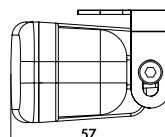
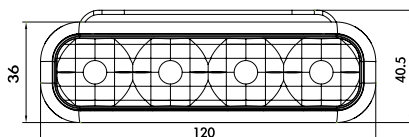
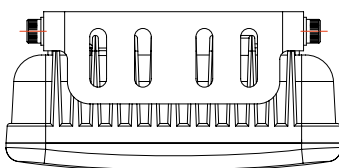
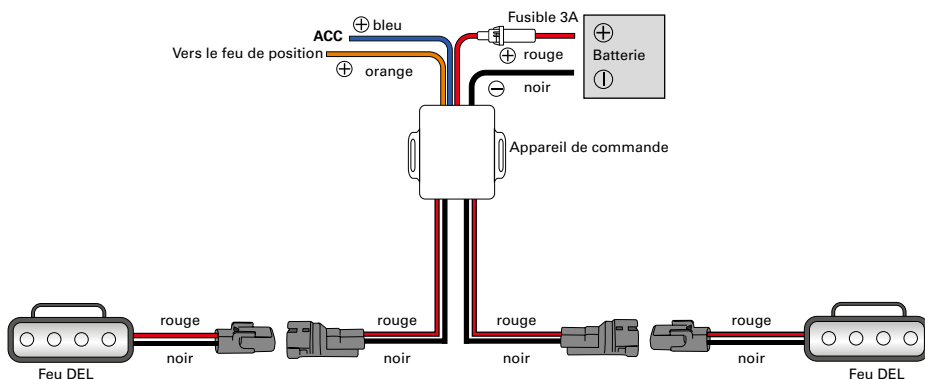

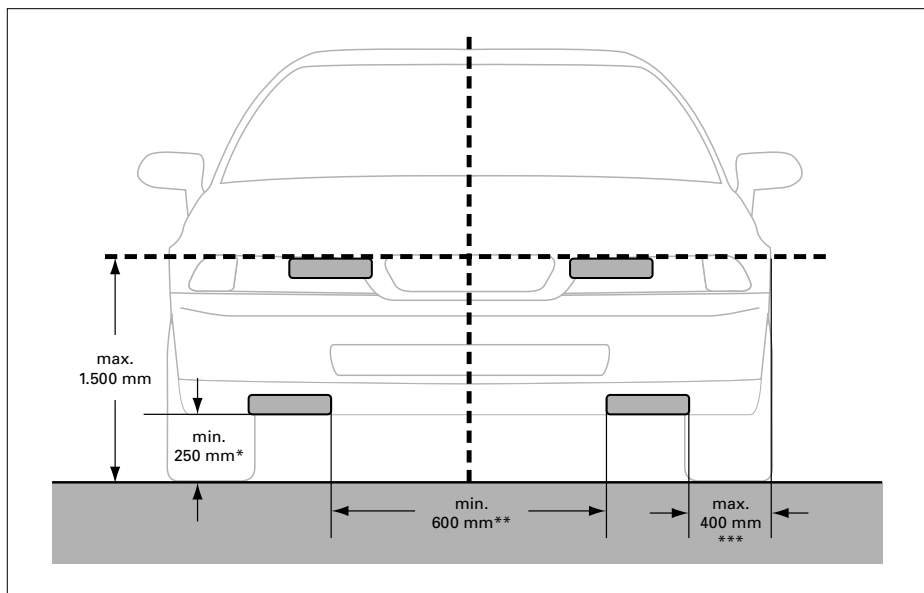

NOTE

- Selon le règlement ECE R-48, seuls deux feux de position, vers l'avant, peuvent être actifs. Si la fonction de feu de position est assurée par les feux LED, les feux de position de série doivent être désactivés.

Montage

- * Si utilisé avec la fonction feu de position, minimum 350 mm.
- ** Sur les véhicules d'une largeur <1 300 mm, la distance minimale doit être de 400 mm.
- *** Si utilisé avec la fonction feu de position, maximum 400 mm. Cette restriction n'est pas applicable si le feu est uniquement utilisé pour la fonction de feu diurne.

Herth+Buss Fahrzeugteile GmbH & Co. KG
Dieselstraße 2-4 | DE-63150 Heusenstamm

Herth+Buss France SAS
ZA Portes du Vercors, 270 Rue Col de La Chau
FR-26300 Châteauneuf-sur-Isère

Herth+Buss Belgium Sprl
Rue de Fisine 9 | BE-5590 Achêne

Herth+Buss UK Ltd
Unit 1 Andyfreight Business Park
Folkes Road, Lye, Stourbridge | UK-DY9 8RB